

1	2	3	4	5	6	7	8				
THIS DRAWING AND THE DATA DISCLOSED HEREIN OR HEREWITH IS NOT TO BE REPRODUCED USED OR DISCLOSED IN WHOLE OR IN PART TO ANYONE WITHOUT THE PERMISSION OF JESS-LINK PRODUCTS CO.,LTD.(JPC)				CUSTOMER DRAWING DRWC-XXXXXX		REV.	ECN NO.	DESCRIPTION	MDF'D	APP'D	DATE
						01		INITIAL DESIGN	Philip	Richard	07/10/2023
						02					
						03					

POSITIONS	02 PIN	03 PIN	04 PIN	05 PIN	06 PIN	07 PIN	08 PIN	10 PIN	14 PIN	16 PIN
VIEW FROM TERMINATION SIDE SOCKET PART										

NOTE:
 1. MATERIAL AND FINISH
 1.1. SHELL ASSEMBLY: COPPER ALLOY, OUTER SHELL AND COLLET NUT Cr PLATING, OTHER METALLIC COMPONENTS Ni PLATING
 1.2. INSULATOR: PEEK
 1.3. CONTACT: COPPER ALLOY, GOLD PLATING
 2. RoHS COMPLIANCE
 3. PART NO.:

R - F 1 B S * * 0 * D 1 * * *

CONTACT POS.	02-16=2pin-16pin
SHELL MATERIAL	0=Brass
CODE	CONTACT TYPE
2	Male Solder Contact
4	Female Solder Contact
C	Crimp Male Contact
M	Crimp Female Contact
COLLET NUT	
1=Nut for fitting a bend relief	

CABLE OD	
42=OD:	3.1mm-4.2mm
52=OD:	4.2mm-5.2mm
62=OD:	5.2mm-6.2mm
72=OD:	6.2mm-7.2mm
76=OD:	7.2mm-7.6mm

CODE	KEY ANGLES
0	0
A	30°
B	60°
..	..

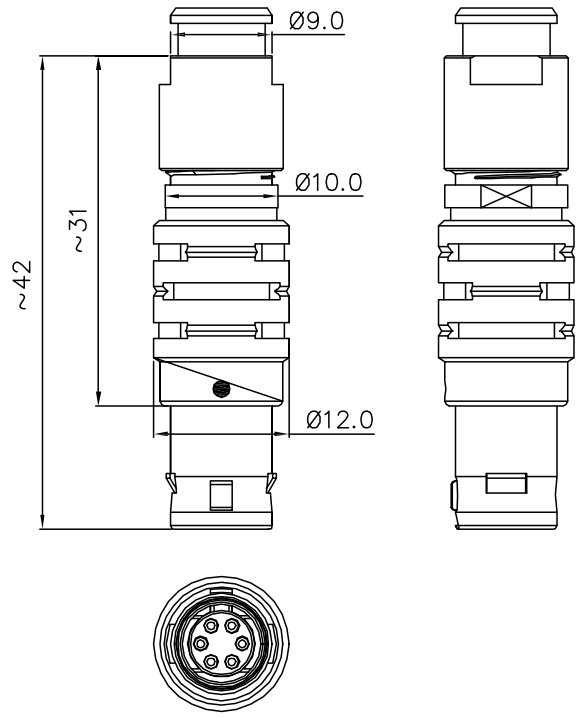

RoHS COMPLIANT	Unit:mm(inch)	PROJECTION	ZCables.com	
	GENERAL TOLERANCES: (UNLESS SPECIFIED)	D.R. 07/10/2023	TITLE	PD./FILE NO.
	0 =±1 (0.039)	Philip	B Series , 1B Size , Straight Plug , 10 Pin , Brass , Male Solder Contact	
	0.0 =±.5 (0.02)	CH.K 07/10/2023	SCALE	SIZE
0.00 =±.3 (0.012)	Philip	1:1	A4	PART NO.
0.000=±.15(0.006)	APV.D 07/10/2023	REV.		REV.
0° =± 2'	Richard	01		01
0.0° =± 1'		SHEET	1 OF 2	

1	2	3	4	5	6	7	8																								
THIS DRAWING AND THE DATA DISCLOSED HEREIN OR HEREWITH IS NOT TO BE REPRODUCED USED OR DISCLOSED IN WHOLE OR IN PART TO ANYONE WITHOUT THE PERMISSION OF JESS-LINK PRODUCTS CO.,LTD.(JPC)				CUSTOMER DRAWING DRWC-XXXXXX		<table border="1"> <tr> <th>REV.</th> <th>ECN NO.</th> <th>DESCRIPTION</th> <th>MDF'D</th> <th>APP'D</th> <th>DATE</th> </tr> <tr> <td>01</td> <td></td> <td>INITIAL DESIGN</td> <td>Philip</td> <td>Richard</td> <td>07/10/2023</td> </tr> <tr> <td>02</td> <td></td> <td></td> <td></td> <td></td> <td></td> </tr> <tr> <td>03</td> <td></td> <td></td> <td></td> <td></td> <td></td> </tr> </table>		REV.	ECN NO.	DESCRIPTION	MDF'D	APP'D	DATE	01		INITIAL DESIGN	Philip	Richard	07/10/2023	02						03					
REV.	ECN NO.	DESCRIPTION	MDF'D	APP'D	DATE																										
01		INITIAL DESIGN	Philip	Richard	07/10/2023																										
02																															
03																															

KEY ANGLES (RECEPTACLE FRONT VIEW):

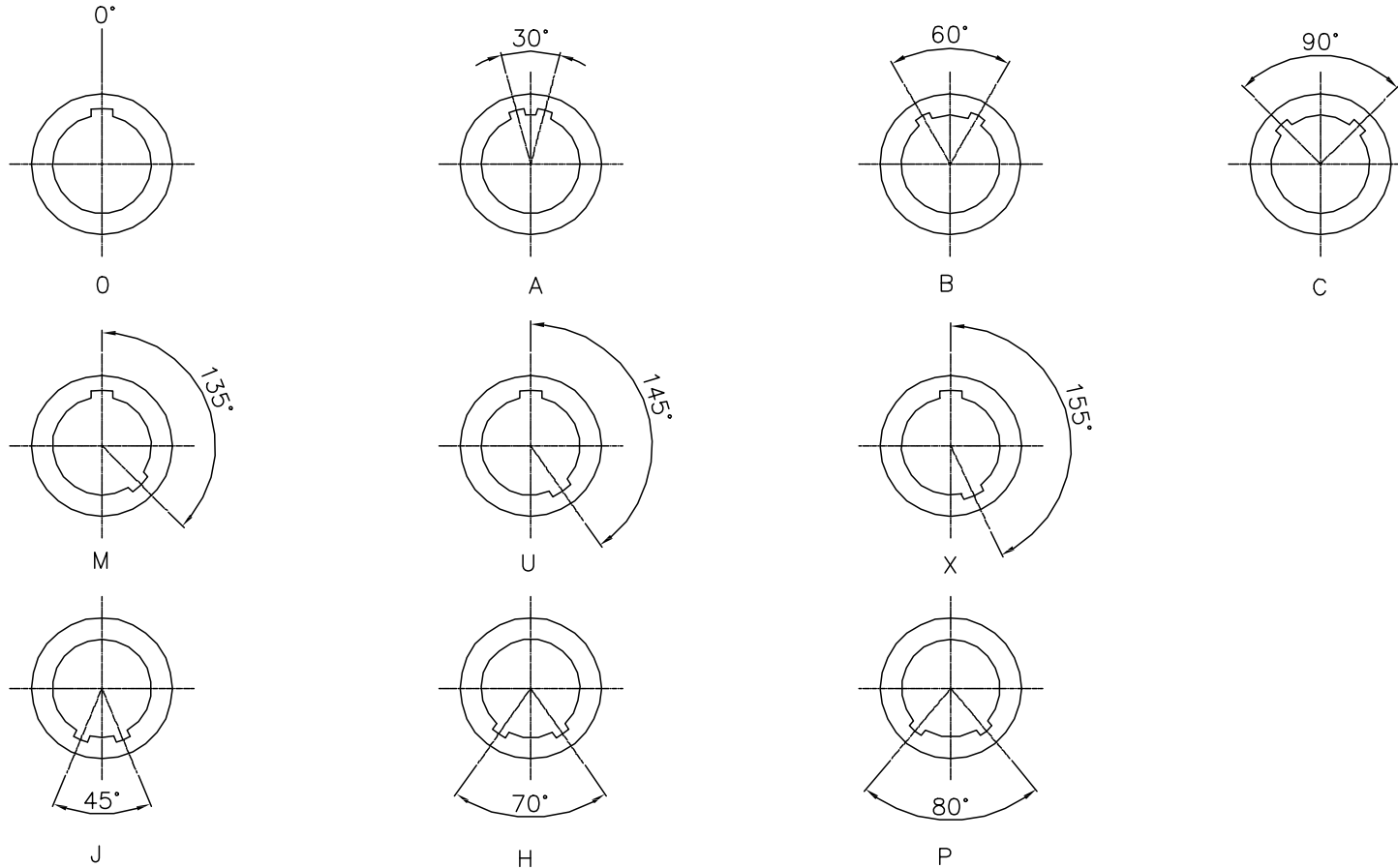

RoHS COMPLIANT	Unit:mm(inch)	PROJECTION 	ZCables.com	
	GENERAL TOLERANCES: (UNLESS SPECIFIED)			
	0 =±1 (0.039)	D.R. 07/10/2023 Philip	TITLE B Series , 1B Size , Straight Plug , 10 Pin , Brass , Male Solder Contact	REV. 01
	0.0 =±.5 (0.02)	CH.K 07/10/2023 Philip	SCALE SIZE PART NO. 1:1 A4 PZACF1BXA12101	SHEET 2 OF 2
0.000=±.15(0.006)	APV.D 07/10/2023 Richard			
0° =± 2'				
0.0° =± 1'				