

THIS DRAWING AND THE DATA DISCLOSED HEREIN OR HEREWITH IS NOT TO BE REPRODUCED USED OR DISCLOSED IN WHOLE OR IN PART TO ANYONE WITHOUT THE PERMISSION OF JESS-LINK PRODUCTS CO.,LTD.(JPC)				CUSTOMER DRAWING		REV.	ECN NO.	DESCRIPTION	MDF'D	APP'D	DATE
						01		INITIAL DESIGN	Jason	Ray	08/29/2019
						02		ADD LABEL	Jason	Ray	10/28/2019
						03		ADD CORK & TABLE 1 & LABEL & PACKAGINA & EEPORM	Winnie	Jason	06/30/2020

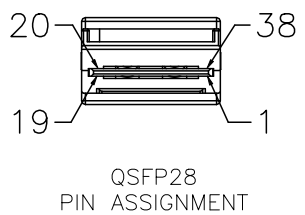
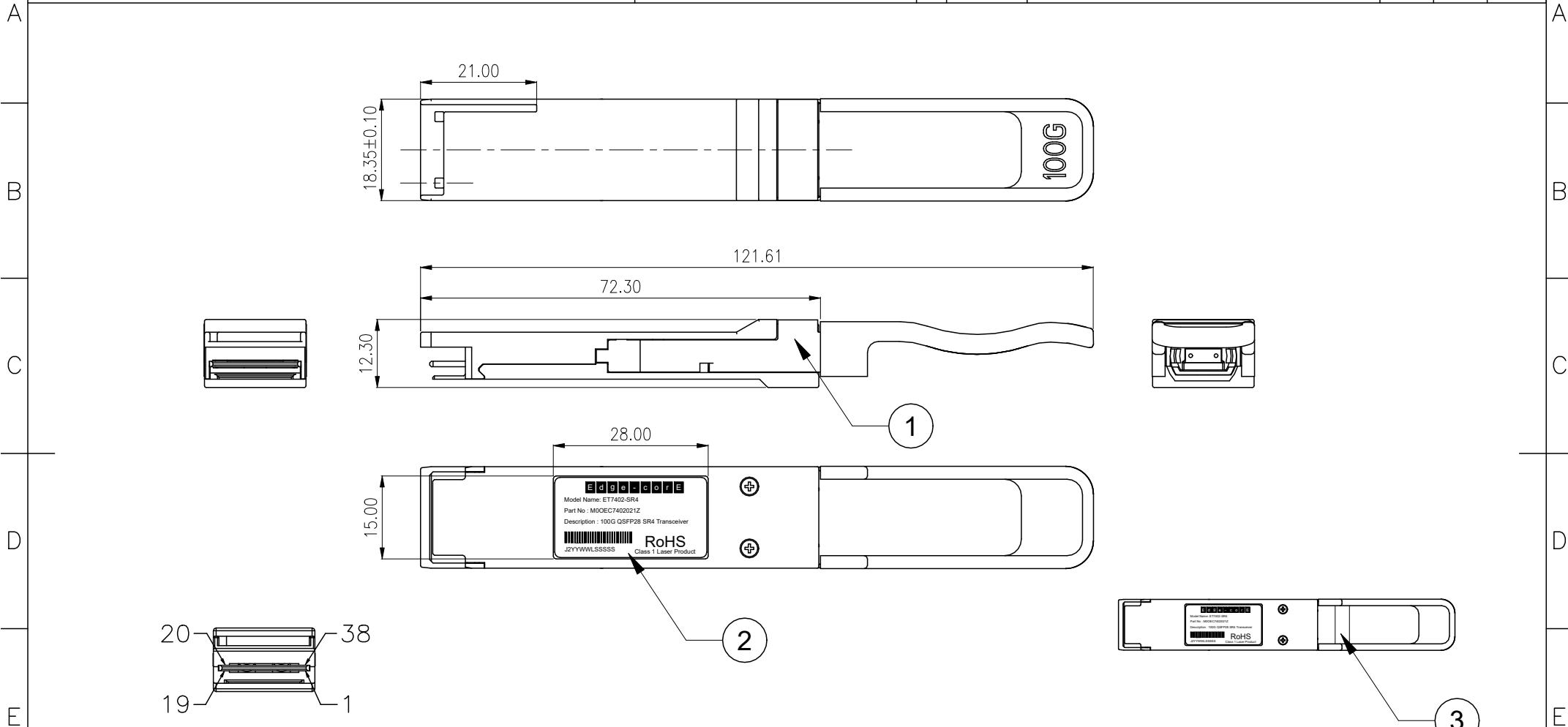

03 TABEL-1

P59080ECCA01-1	ET7402-SR4	M0OEC7402021Z	100G QSFP28 SR4 Transceiver	4712687023147
JPC P/N	EC Model Name	EC's PN	Descriptive Field	EAN CODE

8										
7										
6										
5										
4										
3	PRODUCT CORK								1	
2	TRANSCEIVER MODULE LABEL 1 : FOR SERIAL NO (27.5X14.5mm)								1	
1	QSFP 100G SR4 TRANSCEIVER MODULE								1	
ITEM									Q'TY	

RoHS COMPLIANT

Unit : mm	PROJECTION	JPC connectivity	
GENERAL TOLERANCES: (UNLESS SPECIFIED)	D.R. 08/29/2019 Jason		
0 = ±.50	CH.K 08/29/2019 Albert	QSFP28 100G SR4 TRANSCEIVER MODULE	PRODUCT NO. / LAYOUT C19H0460A
0.0 = ±.25	APV.D 08/29/2019 Ray	SCALE	REV. 03
0.00 = ±.15		1:1	SHEET 1 OF 6
0.000 = ±.05		SIZE	
0° = ± 2°		A4	
0.0° = ± 1°		DWG NO.	
		P59080ECCA01-1	

Pin	Logic	Symbol	Description	Plug Sequence	Notes
1		GND	Ground	1	1
2	CML-I	Tx2n	Transmitter Inverted Data Input	3	
3	CML-I	Tx2p	Transmitter Non-Inverted Data Input	3	
4		GND	Ground	1	1
5	CML-I	Tx4n	Transmitter Inverted Data Input	3	
6	CML-I	Tx4p	Transmitter Non-Inverted Data Input	3	
7		GND	Ground	1	1
8	LVTTTL-I	ModSelL	Module Select	3	
9	LVTTTL-I	ResetL	Module Reset	3	
10		Vcc Rx	+3.3V Power Supply Receiver	2	2
11	LVCMOS-I/O	SCL	2-wire serial interface clock	3	
12	LVCMOS-I/O	SDA	2-wire serial interface data	3	
13		GND	Ground	1	2
14	CML-O	Rx3p	Receiver Non-Inverted Data Output	3	
15	CML-O	Rx3n	Receiver Inverted Data Output	3	
16		GND	Ground	1	1
17	CML-O	Rx1p	Receiver Non-Inverted Data Output	3	
18	CML-O	Rx1n	Receiver Inverted Data Output	3	
19		GND	Ground	1	1
20		GND	Ground	1	1
21	CML-O	Rx2n	Receiver Inverted Data Output	3	
22	CML-O	Rx2p	Receiver Non-Inverted Data Output	3	
23		GND	Ground	1	1
24	CML-O	Rx4n	Receiver Inverted Data Output	3	
25	CML-O	Rx4p	Receiver Non-Inverted Data Output	3	
26		GND	Ground	1	1
27	LVTTTL-O	ModPrsL	Module Present	3	
28	LVTTTL-O	IntL	Interrupt	3	
29		Vcc Tx	+3.3V Power supply transmitter	2	2
30		Vcc1	+3.3V Power supply	2	2
31	LVTTTL-I	LPMODE	Low Power Mode	3	
32		GND	Ground	1	1
33	CML-I	Tx3p	Transmitter Non-Inverted Data Input	3	
34	CML-I	Tx3n	Transmitter Inverted Data Input	3	
35		GND	Ground	1	1
36	CML-I	Tx1p	Transmitter Non-Inverted Data Input	3	
37	CML-I	Tx1n	Transmitter Inverted Data Input	3	
38		GND	Ground	1	1

Pad Assignments And Descriptions

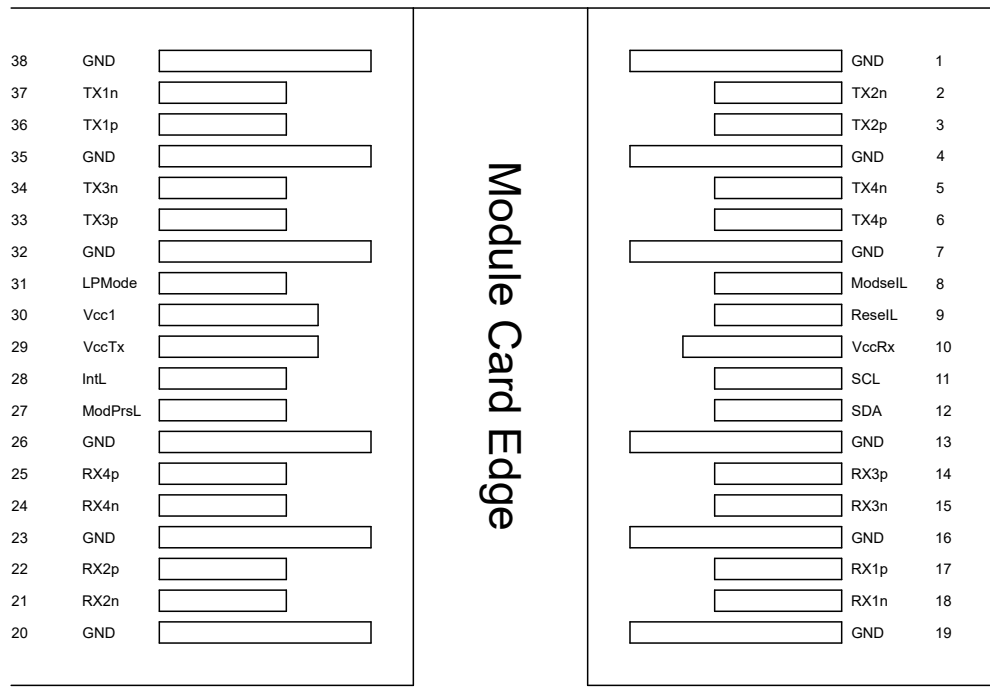

Top Side
Viewed From Top

Bottom Side
Viewed From Bottom

- Notes:
- GND is the symbol for signal and supply (power) common for the QSFP28 module. All are common within the QSFP28 module and all module voltages are referenced to this potential unless otherwise noted. Connect these directly to the host board signal-common ground plane.
 - Vcc Rx, Vcc1 and Vcc Tx are the receiver and transmitter power supplies and shall be applied concurrently. Requirements defined for the host side of the Host Edge Card Connector are listed in Table 6. Recommended host board power supply filtering is shown in Figure 4. Vcc Rx Vcc1 and Vcc Tx may be internally connected within the QSFP28 module in any combination. The connector pins are each rated for a maximum current of 500 mA.

RoHS COMPLIANT	Unit : mm	PROJECTION	JPC connectivity	
	GENERAL TOLERANCES: (UNLESS SPECIFIED)	D.R. 08/29/2019 Jason	TITLE	
	0 = ±.50 0.0 = ±.25 0.00 = ±.15 0.000 = ±.05 0° = ± 2° 0.0° = ± 1°	CH.K 08/29/2019 Albert	QSFP28 100G SR4 TRANSCEIVER MODULE	
		APV.D 08/29/2019 Ray	SCALE 1:1	SIZE A4
				PRODUCT NO. / LAYOUT C19H0460A
				REV. 03
				SHEET 2 OF 6

THIS DRAWING AND THE DATA DISCLOSED HEREIN OR HEREWITH IS NOT TO BE REPRODUCED USED OR DISCLOSED IN WHOLE OR IN PART TO ANYONE WITHOUT THE PERMISSION OF JESS-LINK PRODUCTS CO.,LTD.(JPC)		CUSTOMER DRAWING		REV.	ECN NO.	DESCRIPTION	MDF'D	APP'D	DATE
				01		INITIAL DESIGN	Jason	Ray	08/29/2019
				02		ADD LABEL	Jason	Ray	10/28/2019
				03		ADD CORK & TABLE1 & LABEL & PACKAGINA & EEPORM	Winnie	Jason	06/30/2020

2-Wire Serial Address: 1010000x (A0H)

0	ID and Status	(3 Bytes)
2	Interrupt Flags	(19 Bytes)
21	Module Monitors	(12 Bytes)
33	Channel Monitors	(48 Bytes)
81	Reservrd	(4 Bytes)
85	Control	(12 Bytes)
97	Reservrd	(2 Bytes)
99	Free side Device and Channel Mask	(7 Bytes)
106	Reservrd	(1 Bytes)
107	Free side Device and Properties	(4 Bytes)
111	Reservrd	(7 Bytes)
118	Password Change Entry Area (Optional)	(4 Bytes)
122	Password Entry Area (Optional)	(1 Bytes)(4 Bytes)
125	Page Selected Byte	(1 Bytes)

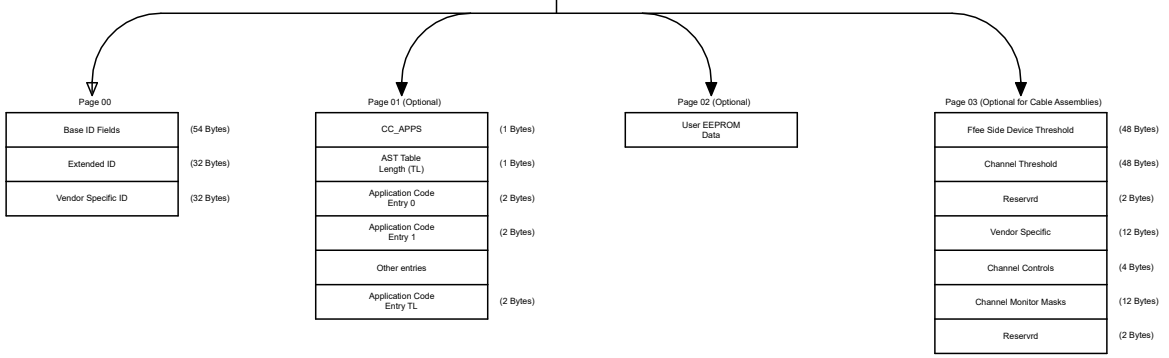

03

RoHS COMPLIANT	Unit : mm	PROJECTION 	JPC connectivity	
	GENERAL TOLERANCES: (UNLESS SPECIFIED)	D.R. 08/29/2019 Jason	TITLE	PRODUCT NO. / LAYOUT
	0 = ±.50 0.0 = ±.25 0.00 = ±.15 0.000 = ±.05 0° = ± 2° 0.0° = ± 1°	CH.K 08/29/2019 Albert	QSFP28 100G SR4 TRANSCEIVER MODULE	C19H0460A
		APV.D 08/29/2019 Ray	SCALE 1:1	DWG NO. P59080ECCA01-1
		SIZE A4	REV. 03	SHEET 3 OF 6

2 - WIRE INTERFACE ID: DATA FIELDS			
Address Byte	Description	Value (HEX)	Note
0	Identifier	00	
1	Revision Compliance	00	
2	Flat_mem, IntL, Data_Not_Ready	00	
3-21	Interrupt Flags	00...	
22-33	Module-Level Monitors	00...	
34-81	Lane-Specific Monitors	00...	
82-85	Reserved	00...	
86-97	Control	00...	
98-99	Reserved	00...	
100-106	Module and channel Masks	00...	
107-118	Reserved	00...	
119-122	Password Change Entry Area	00...	
123-126	Password Entry Area	00...	
127	Page Select Byte	00	
128	Identifier	11	
129	Ext. Identifier	8C	
130	Connector Type	0C	
131-138	Specification Compliance	80 00 00 00 00 00 02 02	
139	Encoding	07	
140	Nominal bit rate, units of 100 Mbps	FF	
141	Extended rateselect Compliance	00	
142	Length(SMF) Link length supported for SMF fiber in km (note 1)	00	
143	Length(OM3 50um)	23	
144	Length(OM2 50um)	00	
145	Length(OM1 62.5 um)	00	
146	Length (passive copper cable). Unit of 1M	32	
147	Device technology	00	
148-163	Vendor Name (ASCII, 16Bytes)	45 64 67 65 63 6F 72 65 4E 65 74 77 6F 72 6B 73	EdgecoreNetworks
164	Extended Module (InfiniBand)	00	
165-167	Vendor OUI (ASCII, 3Bytes)	70 72 CF	
168-183	Vendor PN (ASCII, 16Bytes)	45 54 37 34 30 32 2D 53 52 34 20 20 20 20 20 20	ET7402-SR4
184-185	Vendor rev (ASCII, 2Bytes)	41 30	
186-187	Wave length or Copper cable Attenuation	42 68	
188-189	Wavelength tolerance	07 D0	
190	Maximum Case Temperature	46	
191	CC_BASE (Calculation result of bytes 128-190)	18	
192-195	Options	00...	
196-211	Vendor Serial Number (ASCII, 16Bytes)	4A 32 32 30 31 38 34 30 30 30 31 38 20 20 20 20	J22018400018
212-217	Date Code (ASCII, 6Bytes)	32 30 30 34 32 37	
218-219	Lot Code	20 20	
220	Diagnostic Monitoring Type	0C	
221	Enhanced Options	10	
222	Extended bit rate per lane, units of 250 Mbps.	67	
223	CC_EXT (Calculation result of bytes 192-222)	B9	
224-251	Vendor Specific EEPROM	00...	
252-255	CRC-32 for bytes 128-251	00 00 00 00	



RoHS COMPLIANT	Unit : mm	PROJECTION 	JPC connectivity	
	GENERAL TOLERANCES: (UNLESS SPECIFIED)	D.R. 08/29/2019 Jason	TITLE	
	0 = ±.50 0.0 = ±.25 0.00 = ±.15 0.000 = ±.05 0" = ± 2" 0.0" = ± 1"	CH.K 08/29/2019 Albert	QSF28 100G SR4 TRANSCEIVER MODULE	
		APV.D 08/29/2019 Ray	SCALE 1:1	SIZE A4
				PRODUCT NO. / LAYOUT C19H0460A
				REV. 03
				SHEET 4 OF 6

THIS DRAWING AND THE DATA DISCLOSED HEREIN OR HEREWITH IS NOT TO BE REPRODUCED USED OR DISCLOSED IN WHOLE OR IN PART TO ANYONE WITHOUT THE PERMISSION OF JESS-LINK PRODUCTS CO.,LTD.(JPC)

CUSTOMER DRAWING

REV.	ECN NO.	DESCRIPTION	MDF'D	APP'D	DATE
01		INITIAL DESIGN	Jason	Ray	08/29/2019
02		ADD LABEL	Jason	Ray	10/28/2019
03		ADD CORK & TABLE1 & LABEL & PACKAGINA & EEPORM	Winnie	Jason	06/30/2020

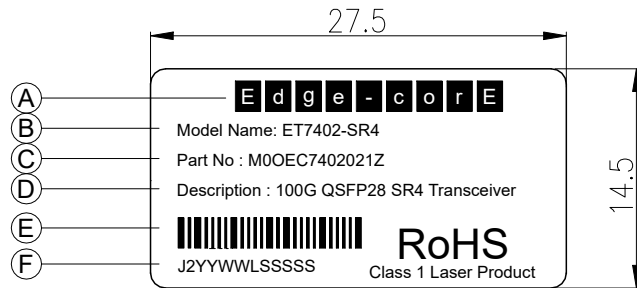

PRODUCT LABEL(2:1)

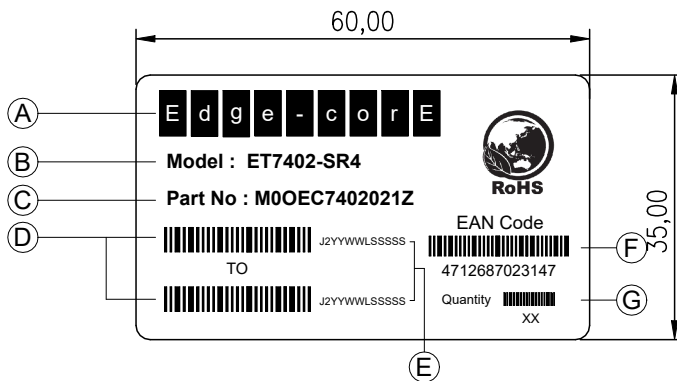

SMALL WHITE BOX LABEL(1:1)

NOTE:

1. PRODUCT LABEL(LABEL INFORMATION CONTENT SEE TABLE 1)

- A.INPUT EDGE-CORE LOGO
- B.Model Name: See Tabel 1 EC Model Number
- C.Part No : See Tabel 1 EC's PN
- D.Description : See Tabel 1 Description
- E.Read INFORMATION F.
- F.J2YYWWLSSSSS
 J2 : JPC CODE (FIXED)
 YY : YEAR /2019 DISPLAY 19
 WW: WEEK
 L = LOACTION(1=HF, 2=KS, 3=TP, 4=WH)
 SSSSS: SERIAL NO.

2. SMALL WHITE BOX LABEL(LABEL INFORMATION CONTENT SEE TABLE 1)

- A.INPUT EDGE-CORE LOGO
- B.Model Name: See Tabel 1 EC Model Number
- C.Part No : See Tabel 1 EC's PN
- D.Read INFORMATION E.
- E.Serial No(Start) To(Stop)
 J2YYWWLSSSSS
 J2 : JPC CODE (FIXED)
 YY : YEAR /2019 DISPLAY 19
 WW: WEEK
 L=LOACTION(1=HF, 2=KS, 3=TP, 4=WH1, 5=WH2)
 SSSSS: SERIAL NO.
- F.EAN Code : See Tabel 1 EAN CODE
- G.Quantity : See D



RoHS COMPLIANT	Unit : mm	PROJECTION	JPC connectivity	
	GENERAL TOLERANCES: (UNLESS SPECIFIED)	D.R. 08/29/2019		
	0 = ±.50	Jason	TITLE	PRODUCT NO. / LAYOUT
	0.0 = ±.25	CH.K 08/29/2019	QSFP28 100G SR4 TRANSCEIVER MODULE	C19H0460A
0.00 = ±.15	Albert	SCALE	SIZE	DWG NO.
0.000 = ±.05	APV.D 08/29/2019	1:1	A4	P59080ECCA01-1
0° = ± 2'	Ray			REV. 03
0.0° = ± 1'				SHEET 5 OF 6

1	2	3	4	5	6	7	8	
THIS DRAWING AND THE DATA DISCLOSED HEREIN OR HEREWITH IS NOT TO BE REPRODUCED USED OR DISCLOSED IN WHOLE OR IN PART TO ANYONE WITHOUT THE PERMISSION OF JESS-LINK PRODUCTS CO.,LTD.(JPC)				CUSTOMER DRAWING				
REV.	ECN NO.	DESCRIPTION				MDF'D	APP'D	DATE
01		INITIAL DESIGN				Jason	Ray	08/29/2019
02		ADD LABEL				Jason	Ray	10/28/2019
03		ADD CORK & TABLE1 & LABEL & PACKAGINA & EEPORM				Winnie	Jason	06/30/2020

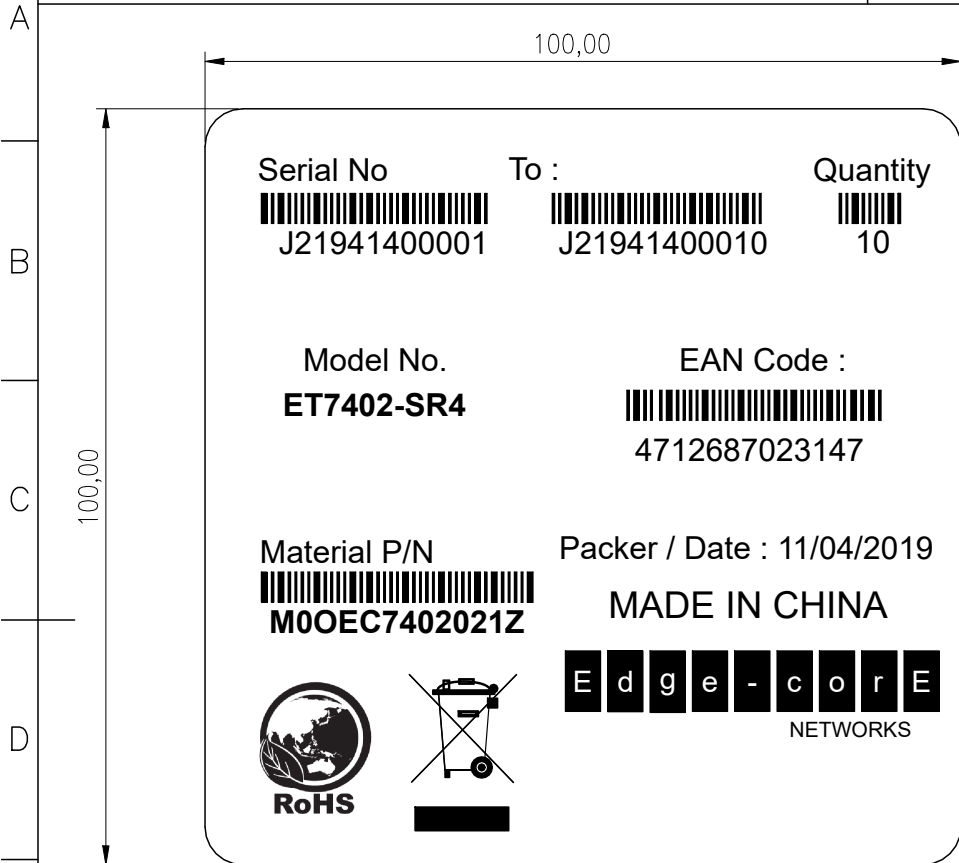

CARTON LABEL

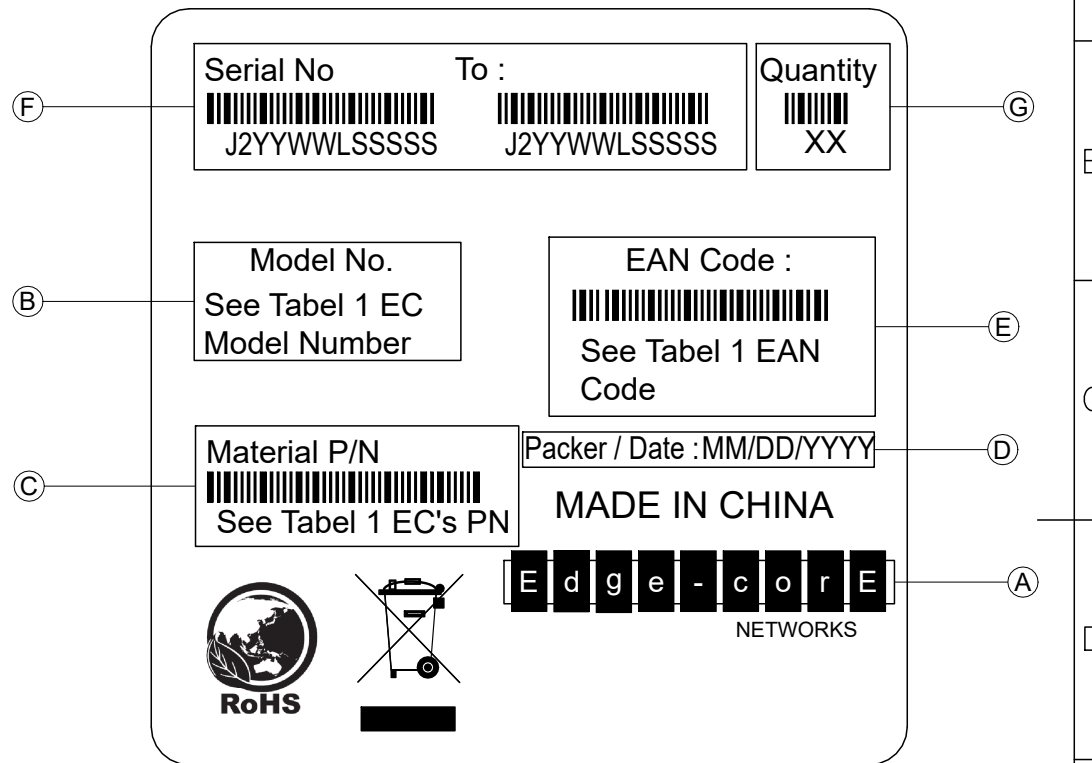

CARTON LABEL(Example)

NOTE:

1. CARTON LABEL(LABEL INFORMATION CONTENT SEE TABLE 1)

- A.INPUT EDGE-CORE LOGO
- B.Model Name: See Tabel 1 EC Model Number
- C.Material P/N : See Tabel 1 EC's PN
- D.Packing date : According to Packing date
- E.EAN Code: See Tabel 1 EAN Code
- F.Serial No(Start) To(Stop)
J2YYWWLSSSSS
J2 : JPC CODE (FIXED)
YY : YEAR /2019 DISPLAY 19
WW: WEEK
L=LOACTION(1=HF, 2=KS, 3=TP, 4=WH1, 5=WH2)
SSSS: SERIAL NO.
- G.Quantity: See F



RoHS COMPLIANT	Unit : mm	PROJECTION	JPC connectivity	
	GENERAL TOLERANCES: (UNLESS SPECIFIED)			
	0 = ±.50 0.0 = ±.25 0.00 = ±.15 0.000 = ±.05 0° = ± 2° 0.0° = ± 1°	D.R. 08/29/2019 Jason CH.K 08/29/2019 Albert APV.D 08/29/2019 Ray	TITLE QSFP28 100G SR4 TRANSCEIVER MODULE	PRODUCT NO. / LAYOUT C19H0460A
		SCALE 1:1 SIZE A4	DWG NO. P59080ECCA01-1	REV. 03 SHEET 6 OF 6

1	2	3	4	5	6	7	8				
THIS DRAWING AND THE DATA DISCLOSED HEREIN OR HEREWITH IS NOT TO BE REPRODUCED USED OR DISCLOSED IN WHOLE OR IN PART TO ANYONE WITHOUT THE PERMISSION OF JESS-LINK PRODUCTS CO.,LTD.(JPC)				CUSTOMER DRAWING		REV.	ECN NO.	DESCRIPTION	MDF'D	APP'D	DATE
						01		INITIAL DESIGN	Jason	Ray	08/29/2019
						02		ADD LABEL	Jason	Ray	10/28/2019
						03		ADD CORK & TABLE1 & LABEL & PACKAGINA & EEPORM	Winnie	Jason	06/30/2020

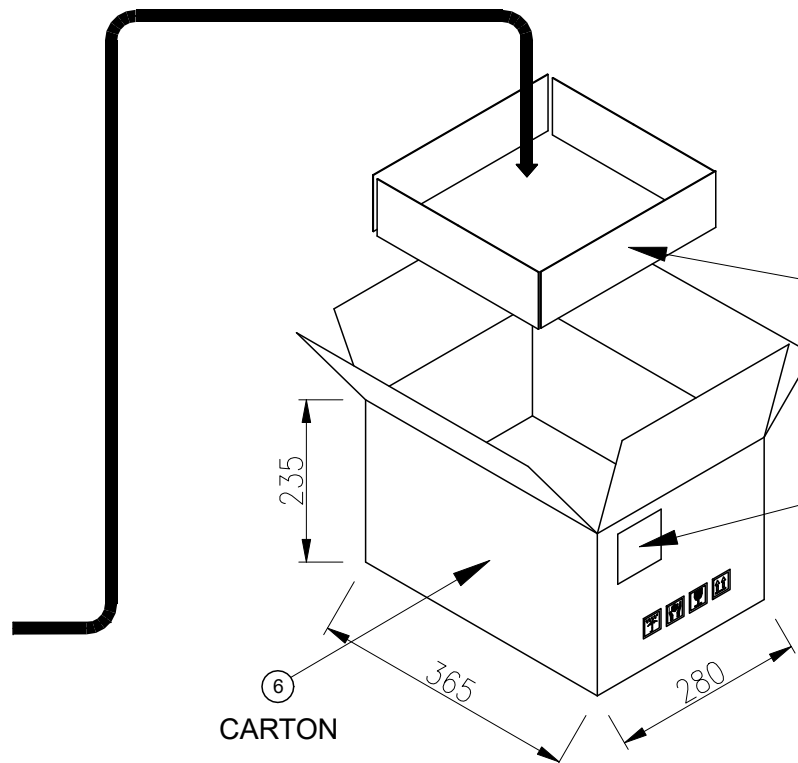
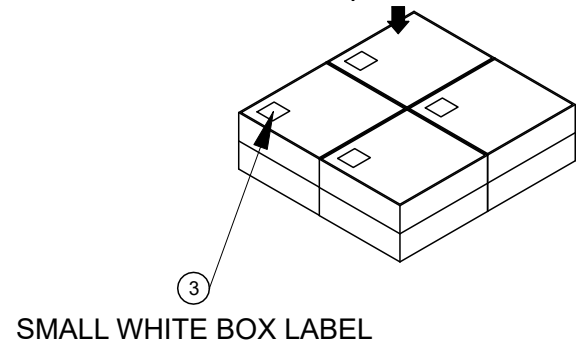
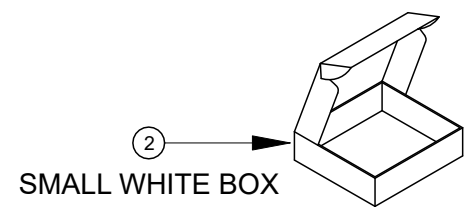
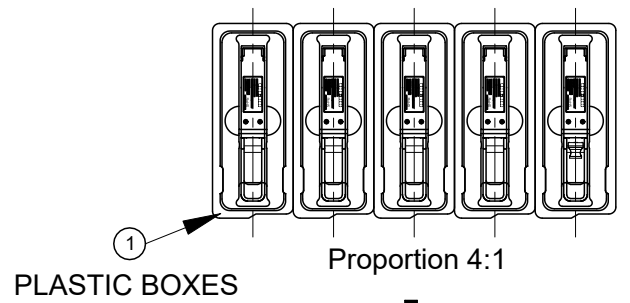

⑤ PEARL COTTON WHITE

④ CARTON LABEL

03

8											
7											
6	CARTON (365mm*280mm*235mm)				1						
5	PEARL COTTON WHITE				6						
4	CARTON LABEL : FOR SERIAL NO (100X100mm)				1						
3	SMALL WHITE BOX LABEL : FOR SERIAL NO (60X35mm)				8						
2	SMALL WHITE BOX (10pcs PLASTIC BOXES/SMALL WHITE BOX)				8						
1	PLASTIC BOXES(10PCS PRODUCT/PLASTIC BOXES)				80						
ITEM					Q'TY						

RoHS COMPLIANT

Unit : mm
GENERAL TOLERANCES: (UNLESS SPECIFIED)
0 = ±.50
0.0 = ±.25
0.00 = ±.15
0.000 = ±.05
0° = ± 2°
0.0° = ± 1°

PROJECTION
D.R. 08/29/2019
Jason
CH.K 08/29/2019
Albert
APV.D 08/29/2019
Ray

JPC connectivity

TITLE		PRODUCT NO. / LAYOUT	
QSFP28 100G SR4 TRANSCEIVER MODULE		C19H0460A	
SCALE	SIZE	DWG NO.	REV.
1:1	A4	P59080ECCA01-1	03
			SHEET 7 OF 6