

THIS DRAWING AND THE DATA DISCLOSED HEREIN OR HEREWITH IS NOT TO BE REPRODUCED USED OR DISCLOSED IN WHOLE OR IN PART TO ANYONE WITHOUT THE PERMISSION OF JESS-LINK PRODUCTS CO.,LTD.(JPC)

CUSTOMER DRAWING
DRWC-000XXX

REV.	ECN NO.	DESCRIPTION	MDF'D	APP'D	DATE
01		INITIAL DESIGN	Denghong	Richard	07/06/2023

Standard part List(WITHOUT HVIL)
產品型號表(不帶護鎖)

Model No.	Polarization
TL00X-500-20M8	X
TL00Y-500-20M8	Y
TL00U-500-20M8	U
TL00V-500-20M8	V
TL00W-500-20M8	W
TL00T-500-20M8	T
TL00X-500-20M10	X
TL00Y-500-20M10	Y
TL00U-500-20M10	U
TL00V-500-20M10	V
TL00W-500-20M10	W
TL00T-500-20M10	T

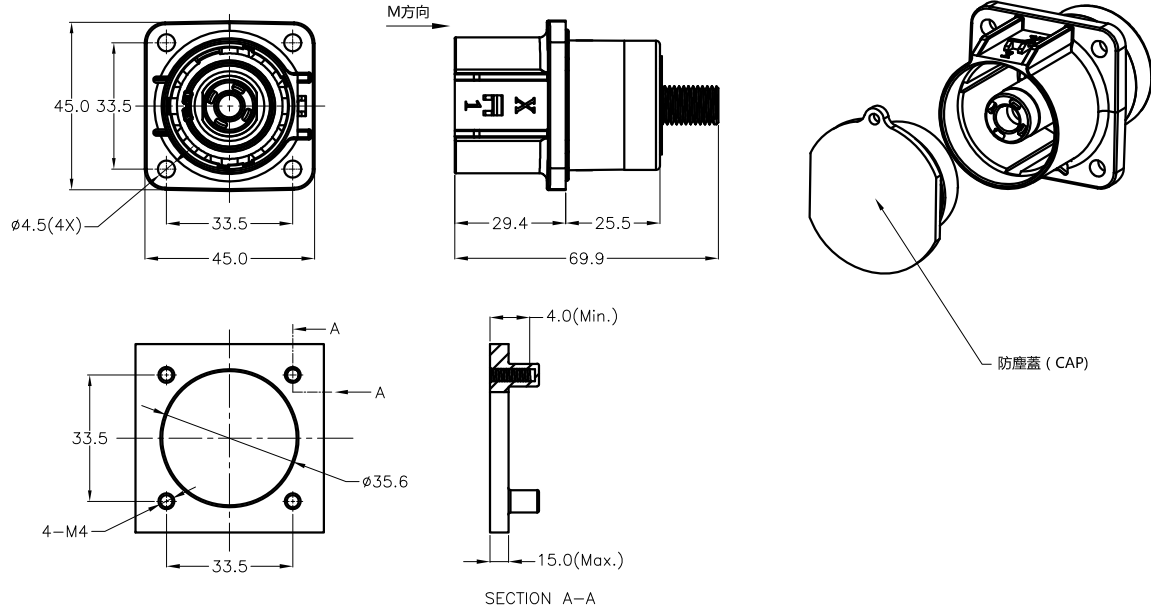

NOTE1 :

- 1.工作温度 Operating temperature : -40°C ~ +125°C.
- 2.带高压互锁 Electrical interlock (HVIL).
- 3.额定电流 Current rating:Power:500A ; HVIL:5A;
- 4.额定电压 Operating voltage:Power:1000 VDC;Signal:60 VDC.
- 5.耐电压 Dielectric withstanding voltage:
 - A.与插头对插后, Pin与铁壳之间:After matting,between Pin and metal shell:5000 VDC.
 - B.与插头对插后, Pin与HVIL之间:After matting,between Pin and HVIL:5000 VDC.
 - C.与插头对插后, HVIL与铁壳之间:After matting,between HVIL and metal shell:500 VDC.
 - D.与插头对插前, 两个HVIL端子之间耐压:Before matting,between two HVIL :500 VDC.
- 6.防护等级 Protection class:IP68(24H) , IP6K9K.
- 7.电磁屏蔽 Shielding.
- 8.机械寿命 Mating cycle:100 Min.
- 9.带自动二次锁扣 Automatic secondary lock.
- 10.铜排推荐安装扭矩 Recommended Fasten Torque on lug:
M6: 3.6 ~ 4.4 Nm M8: 7.2 ~ 8.8 Nm M10: 17.1 ~ 20.9 Nm
- 11.推荐法兰盘螺丝安装扭矩 Recommended Screw Assembly Torque on Flange : 1.6 ~ 2.4 Nm
- 12.配对插头 Mating plug:See drawing "TL28/18X-500/501-XX".

NOTE2 :

- 1.All non-dimensioned surfaces according to 3D-model
- 2.planesness of panel surface should less than or equal to 0.1mm
- 3.Roughness of panel surface should be $\sqrt{6.3}$ or better
- 4.thickness of panel should not exceed 15mm

訂購信息 Ordering Information

T L 0 0 X - 5 0 0 - 2 0 M 1 0

鍵位及顏色 Key&Color	高壓互鎖 HVIL	端子類型 Type	接線孔類型&大小 Size
"X" 橙色 Orange "Y" 黑色 Black "U" 黃色 Yellow "V" 綠色 Green "W" 紅色 Red "T" 藍色 Blue	0,不帶互鎖 No HVIL 1,帶互鎖 With HVIL	20" 螺柱	M10 or M8

M方向鍵位示意圖

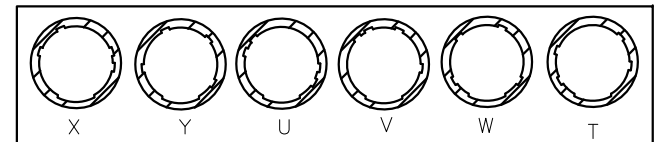

RoHS COMPLIANT HALOGEN FREE	Unit : mm	PROJECTION	ZCables.com		PD./FILE NO.	
	GENERAL TOLERANCES: (UNLESS SPECIFIED)	D.R. 07/06/2023 Denghong	TITLE	TL00(X)-500-20XXX		
	0 = ±.50 0.0 = ±.25 0.00 = ±.15 0.000 = ±.05 0' = ±.2' 0.0' = ±.1'	CH.K	SCALE	SIZE	PART NO.	REV. 01
		APV.D	1:1	A4	See Notes	SHEET 1 OF 1