

**TITLE****1Gbps SFP Bi-Directional Transceiver, 20km Reach  
1310nm TX / 1550 nm RX****1. SCOPE**

The Product Small Form Factor Pluggable (SFP) transceiver module is specifically designed for the high performance integrated duplex data link over single-mode. These transceiver modules are compliant with the SFP Multisource Agreement (MSA). With the hot plug ability, these modules offer an easy way to be installed into SFP MSA compliant ports at any time without the interruption of the host equipment operating online. The 1G BiDi SFP transceivers using a long wavelength (1310nm) FP laser diode enable data transmission up to 20km on a single-mode (9/125µm) optical fiber.

**2. PRODUCT DESCRIPTION****2.1 PRODUCT NAME AND SERIES NUMBER(S)****SFP 1G BiDi Transceiver**

Part Number	Data Rate	Wavelength (nm)	Distance	Media	Power (dBm)	Sen. (dBm)	Connector	Tem.
ZFTBBCB3155A2ST	1G	1310	20 km	SMF	-9~-3	-23	LC	C

## TITLE

**1Gbps SFP Bi-Directional Transceiver, 20km Reach  
1310nm TX / 1550 nm RX**

### 2.2 DIMENSIONS, MATERIALS, PLATINGS AND MARKING

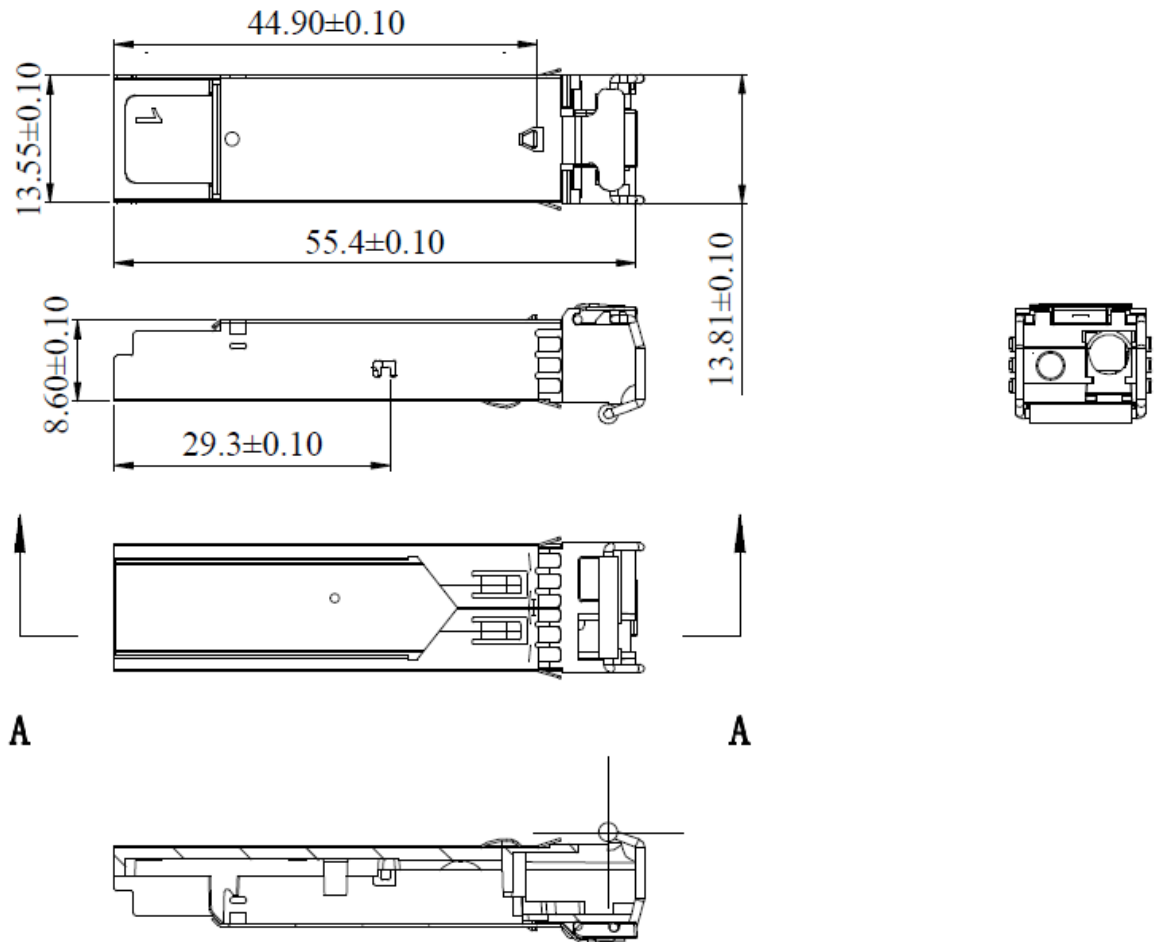

### 3. APPLICABLE DOCUMENTS AND SPECIFICATIONS

- Compliant with SFP MSA
- SONET OC-24-LR-1

### 4. QUALIFICATION

- Electrostatic Discharge (ESD) to the Electrical Pins
- Electrostatic Discharge (ESD) to the Duplex LC Receptacle
- RoHS compliance

**TITLE**

**1Gbps SFP Bi-Directional Transceiver, 20km Reach  
1310nm TX / 1550 nm RX**

## 5. Absolute Maximum Ratings & Recommended Operating Conditions

### Absolute Maximum Ratings

Parameter	Symbol	Min.	Max.	Unit
Storage Temperature	TS	-40	+85	°C
Supply Voltage	VCC3	-0.5	4	V
Relative Humidity(Non-condensing)	RH	5	95	%

### Recommended Operating Conditions

Parameter	Symbol	Min.	Typical	Max.	Unit
Operating Case Temperature(I-temp)	T <sub>I</sub>	-40		85	°C
Operating Case Temperature(C-temp)	T <sub>C</sub>	0		70	°C
Power Supply Voltage	VCC3	3.1	3.3	3.5	V
Power Supply Current	I <sub>cc</sub>			300	mA
Data Rate			1.25		Gbps
Transmission Distance	SMF			20	km

### Transmitter Operating Characteristic-Optical, Electrical

Parameter	Symbol	Min.	Typical	Max.	Unit	Note
Center Wavelength	λ <sub>C</sub>	1290	1310	1330	nm	Note1
Laser Off Power	P <sub>off</sub>	-	-	-30	dBm	
Average Optical Power	P <sub>avg</sub>	-9	-	-3	dBm	
RMS spectral width				4	nm	
Optical Rise/Fall Time (20%~80%)	tr/tf			0.26	ns	
Extinction Ratio	ER	9	-	-	dB	
Transmitter Dispersion Penalty	TDP	-	-	1	dB	
Operating Data Rate			1.25		Gbps	

**TITLE**

**1Gbps SFP Bi-Directional Transceiver, 20km Reach  
1310nm TX / 1550 nm RX**

Optical Eye Mask Margin			5			%	
Tx Input Diff Swing		VI	400		1800	mV	
Tx_Disable	Disable		2		VCC	V	
	Enable		VEE		VEE+ 0.8	V	

Notes:

1. Average optical power shall be measured using the methods specified in TIA/EIA-455-95.

**Receiver Operating Characteristic-Optical, Electrical**

Parameter	Symbol	Min.	Typ.	Max.	Unit	Note
Center Wavelength	$\lambda_r$	1530	1550	1570	nm	
Receiver Sensitivity (OMA)				-23	dBm	1
LOS Assert	LOS A	-30		-	dBm	
LOS Dessert	LOS D			-21	dBm	
LOS Hysteresis	LOSH	0.5		6	dB	
Overload	Pin	-3			dBm	
Return Loss of Receiver		12			dB	
Operating Data Rate			1.25		Gbps	
Rx Output Diff Swing	Vo	400		1800	mV	

Notes:

1. Receiver sensitivity is informative. shall be measured with conformance test signal for BER =  $1 \times 10^{-12}$ .

**Control and Status I/O Timing Characteristics**

Parameter	Symbol	Min.	Max.	Unit	Note
TX Disable Assert Time	t_off		100	$\mu$ s	Note1
TX Disable Negate Time	t_on		2	ms	Note2
Time to initialize including reset of TX_Fault	t_init		300	ms	Note3
TX Fault Assert Time	t_fault		1	ms	Note4
Tx_Fault Reset	t_reset	10		$\mu$ s	Note5

**TITLE**

**1Gbps SFP Bi-Directional Transceiver, 20km Reach  
1310nm TX / 1550 nm RX**

LOS Assert Time	t_loss_on		100	μs	Note6
LOS Deassert Time	t_loss_off		100	μs	Note7
Serial ID Clock Rate	f_serial_clock	100	400	kHz	

*Notes:*

1. Time from rising edge of TX Disable to when the optical output falls below 10% of nominal
2. Time from falling edge of TX Disable to when the modulated optical output rises above 90% of nominal
3. From power on or negation of TX Fault using TXDisable
4. Time from fault to TX fault on
5. Time TX Disable must be held high to reset TX\_fault
6. Time from LOS state to RX LOS assert
7. Time from non-LOS state to RX LOS deassert.
8. Time from rising or falling edge of Rate Select input until receiver bandwidth is in conformance with appropriate specification.

**6. Pin-out Definition:**

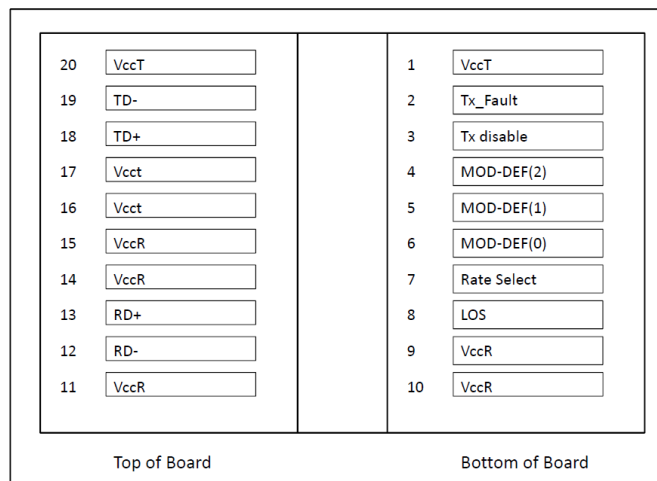

**Pin Definitions**

**TITLE**

**1Gbps SFP Bi-Directional Transceiver, 20km Reach  
1310nm TX / 1550 nm RX**

**Pin Assignment**

Pin	Symbol	Name/Description	Note
1	VeeT	Module Transmitter Ground	1
2	TX_Fault	Module Transmitter Fault	3
3	TX_Disable	Transmitter Disable; Turns off transmitter laser output	3
4	SDA	2-wire Serial Interface Data Line (Same as MOD-DEF2 as defined in the INF-8074i)	3
5	SCL	2-wire Serial Interface Clock (Same as MOD-DEF1 as defined in the INF-8074i)	3
6	MOD_ABS	Module Absent, connected to VeeT or VeeR in the module	3
7	RS	Rate select, optionally controls SFP module receiver. When High input data rate 10.3GBd and when LOW data-rate 1.25GBd.	3
8	RX_LOS	Receiver Loss of Signal Indication (In FC designated as RX_LOS, in SONET designated as LOS, and in Ethernet designated at Signal Detect)	3
9	VeeR	Module Receiver Ground	1
10	VeeR	Module Receiver Ground	1
11	VeeR	Module Receiver Ground	1
12	RD-	Receiver Inverted Data Output	3
13	RD+	Receiver Non-Inverted Data Output	3
14	VeeR	Module Receiver Ground	1
15	VccR	Module Receiver 3.3 V Supply	2
16	VccT	Module Transmitter 3.3 V Supply	2
17	VeeT	Module Transmitter Ground	1
18	TD+	Transmitter Non-Inverted Data Input	3
19	TD-	Transmitter Inverted Data Input	3
20	VeeT	Module Transmitter Ground	

**TITLE**

**1Gbps SFP Bi-Directional Transceiver, 20km Reach  
1310nm TX / 1550 nm RX**

**Block Diagram of Transceiver**

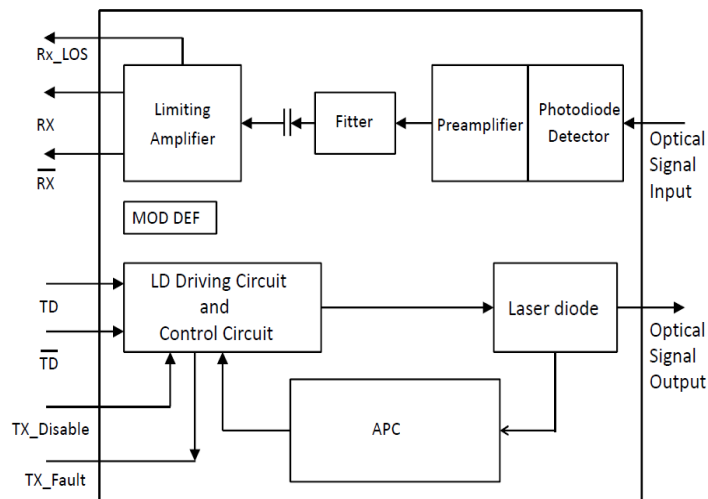

**Block Diagram of Transceiver**

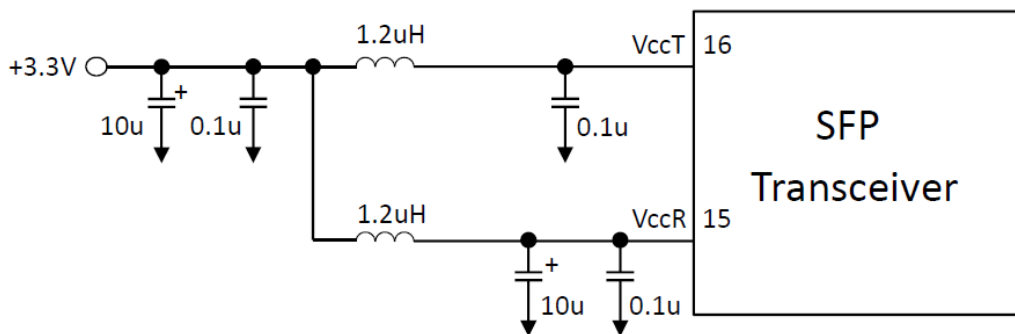

**Recommended Interface Circuit**