

TITLE**1Gbps SFP Bi-Directional Transceiver, 40km Reach
1550nm TX / 1310 nm RX***SCOPE*

The SFP-BIDI transceivers are high performance, cost effective modules supporting dual data-rate of 1.25Gbps/1.0625Gbps and 40km transmission distance with SMF.

The transceiver consists of three sections: a DFB laser transmitter, a PIN photodiode integrated with a trans-impedance preamplifier (TIA) and MCU control unit. All modules satisfy class I laser safety requirements.

The transceivers are compatible with SFP Multi-Source Agreement (MSA) and SFF-8472. For further information, please refer to SFP MSA.

1. PRODUCT FEATURES

- Dual Data-Rate of 1.25Gbps/1.063Gbps Operation
- 1490nm DFB Laser and Pin Photo detector for 40km Transmission
- Compliant with SFP MSA and SFF-8472 WITH Duplex LC Receptacle
- Digital Diagnostic Monitoring : Internal Calibration or External Calibration
- Compatible with SONET OC-24-LR-1
- Compatible with RoHS
- +3.3V Single Power Supply
- Operating Case Temperature : 0 to 70°C // -40 to +85°C

2. PRODUCT DESCRIPTION**2.1 PRODUCT NAME AND SERIES NUMBER(S)****SFP 1G BiDi 40km Transceiver**

Part Number	Data Rate	Wavelength (nm)	Distance	Media	Power (dBm)	Sen. (dBm)	Connector	Tem.
ZFTBBDB5531A3ST	1G	1550	40 km	SMF	-5 ~ 0	-23	LC	C

TITLE

**1Gbps SFP Bi-Directional Transceiver, 40km Reach
1550nm TX / 1310 nm RX**

2.2 DIMENSIONS, MATERIALS, PLATINGS AND MARKING

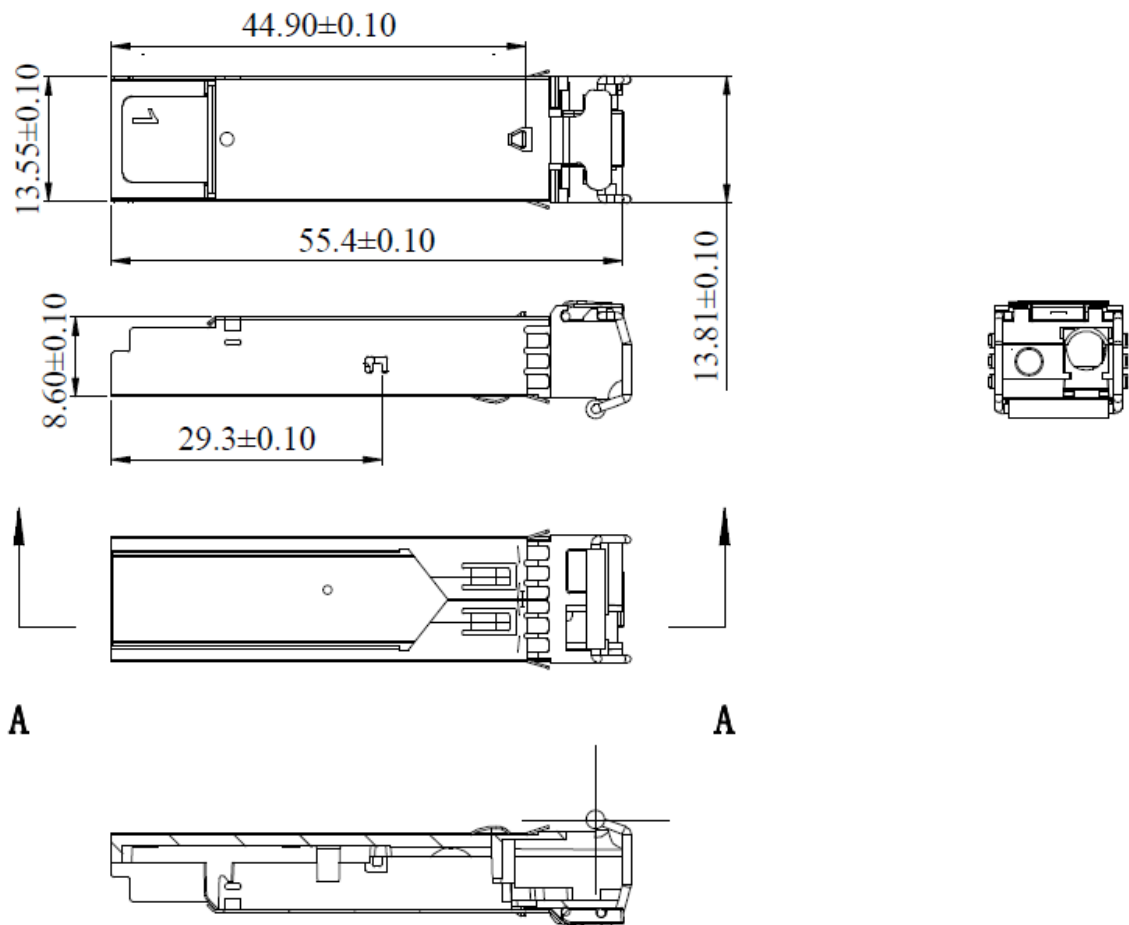

3. APPLICABLE DOCUMENTS AND SPECIFICATIONS

- Gigabit Ethernet
- Fiber Channel
- Switch to Switch Interface
- Switched Backplane Applications
- Router/Server Interface
- Other Optical Transmission Systems

TITLE

**1Gbps SFP Bi-Directional Transceiver, 40km Reach
1550nm TX / 1310 nm RX**

4. Absolute Maximum Ratings & Recommended Operating Conditions

Absolute Maximum Ratings

Parameter	Symbol	Min.	Max.	Unit
Storage Temperature	TS	-40	+85	°C
Supply Voltage	VCC3	-0.5	4	V
Relative Humidity(Non-condensing)	RH	5	85	%

Recommended Operating Conditions

Parameter	Symbol	Min.	Typical	Max.	Unit
Operating Case Temperature(C-temp)	TC	0		70	°C
Operating Case Temperature(I-temp)	TI	-40		85	°C
Power Supply Voltage	VCC3	3.1	3.3	3.5	V
Power Supply Current	Icc			300	mA
Data Rate	Gigabit Ethernet		1.25		Gbps
	Fiber Channel		1.063		

Transmitter Operating Characteristic-Optical, Electrical

Parameter	Symbol	Min.	Typical	Max.	Unit	Note
Center Wavelength	λ_C	1530	1550	1570	nm	
Spectral Width(-20dB)	$\Delta\lambda$	-	-	1	nm	
Side Mode Suppression Ratio	Poff	30	-	-	dB	
Average Optical Power	Pavg	-5	-	0	dBm	1
Extinction Ratio	ER	9	-	-	dB	
Optical Rise/Fall Time (20%~80%)	-	-	-	0.26	ns	
Data Input Swing Differential	-	400	-	1800	mV	2
Input Differential Impedance	VI	90	100	110	Ω	

TITLE

**1Gbps SFP Bi-Directional Transceiver, 40km Reach
1550nm TX / 1310 nm RX**

Tx_Disable	Disable	-	2.0	-	VCC	V	
	Enable	-	VEE	-	VEE+ 0.8	V	
Tx_Fault	Disable	-	2.0	-	VCC	V	
	Enable	-	VEE	-	VEE+ 0.8	V	

Notes:

1. The Optical Power is Launched into SMF
2. PECL Input, Internally AC-Coupled and Terminated

Receiver Operating Characteristic-Optical, Electrical						
Parameter	Symbol	Min.	Typ.	Max.	Unit	Note
Center Wavelength	λ_r	1290	1310	1330	nm	
Receiver Sensitivity	-	-	-	-23	dBm	1
Receiver Overload	-	-3	-	-	dBm	1
LOS De-Assert	LOS A	-	-	-24	dBm	
LOS Assert	LOS D	-30	-	-	dBm	
LOS Hysteresis	LOSH	1	-	4	dB	
Return Loss of Receiver		400	-	1800	mV	2
LOS	High	2.0		Vcc	V	
	Low	-	-	0.8	V	

Notes:

1. Measured with a PRBS 2⁷-1 Test Pattern @1250Mbps. BER = 1×10^{-12} .
2. Internally AC-Coupled.

Control and Status I/O Timing Characteristics					
Parameter	Symbol	Min.	Typical	Max	Unit
TX Disable Assert Time	t_off			1	ms
TX Disable Negate Time	t_on			10	μ s
Time to initialize including reset of TX_Fault	t_init			300	ms

TITLE

**1Gbps SFP Bi-Directional Transceiver, 40km Reach
1550nm TX / 1310 nm RX**

TX Fault Assert Time	t_fault			100	μs
TX Disable to Reset	t_reset	10			μs
LOS Assert Time	t_loss_on			100	μs
LOS De-assert Time	t_loss_off			100	μs
Serial ID Clock Rate	f_serial_clock			400	kHz
MOD_DEF (0:2)-High	V _H	2		V _{cc}	V
MOD_DEF (0:2)-Low	V _L			0.8	V

Diagnostics

Parameter	Symbol	Min.	Typical	Max
Temperature	-40 to +85	°C	±3°C	Internal / External
Voltage	3.0 to 3.6	V	±3%	Internal / External
Bias Current	0 to 100	mA	±10%	Internal / External
TX Power	-5 to 0	dBm	±3dB	Internal / External
Rx Power	-23 to -3	dBm	±3dB	Internal / External

5. Pin-out Definition:

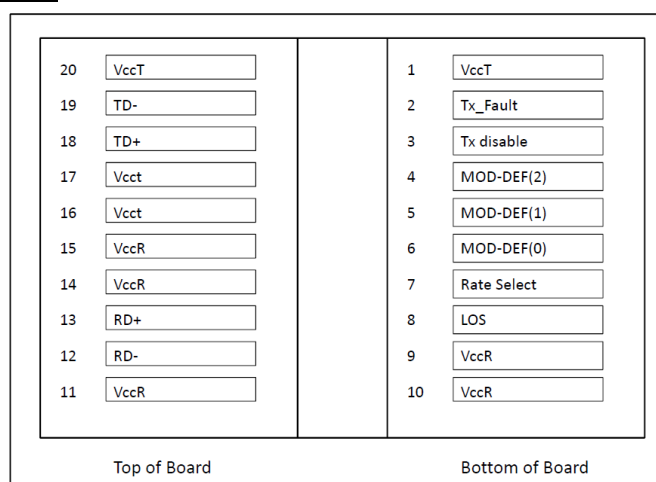

Pin Definitions

TITLE

**1Gbps SFP Bi-Directional Transceiver, 40km Reach
1550nm TX / 1310 nm RX**

Pin Assignment

Pin	Symbol	Name/Description	Plug Seq.	Notes
1	VeeT	Module Transmitter Ground	1	
2	TX_Fault	Module Transmitter Fault	3	1
3	TX_Disable	Transmitter Disable; Turns off transmitter laser output	3	2
4	MOD_DEF(2)	2-wire Serial Interface Data Line (Same as MOD-DEF2 as defined in the INF-8074i)	3	3
5	MOD_DEF(1)	2-wire Serial Interface Clock (Same as MOD-DEF1 as defined in the INF-8074i)	3	3
6	MOD_DEF(0)	Module Absent, connected to VeeT or VeeR in the module	3	3
7	RS	Rate select, optionally controls SFP module receiver. When High input data rate 10.3GBd and when LOW data-rate 1.25GBd.	3	
8	RX_LOS	Receiver Loss of Signal Indication (In FC designated as RX_LOS, in SONET designated as LOS, and in Ethernet designated at Signal Detect)	3	4
9	VeeR	Module Receiver Ground	1	
10	VeeR	Module Receiver Ground	1	
11	VeeR	Module Receiver Ground	1	
12	RD-	Receiver Inverted Data Output	3	5
13	RD+	Receiver Non-Inverted Data Output	3	5
14	VeeR	Module Receiver Ground	1	
15	VccR	Module Receiver 3.3 V Supply	2	
16	VccT	Module Transmitter 3.3 V Supply	2	
17	VeeT	Module Transmitter Ground	1	
18	TD+	Transmitter Non-Inverted Data Input	3	6
19	TD-	Transmitter Inverted Data Input	3	6
20	VeeT	Module Transmitter Ground	1	

Notes:

1. TX Fault is an open collector output, which should be pulled up with a 4.7k~10kΩ resistor on the host board to a voltage between 2.0V and Vcc+0.3V. Logic 0 indicates normal operation; Logic 1 indicates a laser fault of some kind. In the low state, the output will be pulled to less than 0.8V.
2. TX Disable is an input that is used to shut down the transmitter optical output. It is pulled up within the

TITLE

1Gbps SFP Bi-Directional Transceiver, 40km Reach 1550nm TX / 1310 nm RX

module with a 4.7k~10kΩ resistor. Its states are:

Low(0 to 0.8V): Transmitter on
 (>0.8V,< 2.0V): Undefined
 High(2.0 to 3.465V): Transmitter Disabled
 Open: Transmitter Disabled

3. Mod-Def 0,1,2. These are the module definition pins. They should be pulled up with a 4.7k~10kΩ resistor on the host board. The pull-up voltage shall be VccT or VccR.
 Mod-Def 0 is grounded by the module to indicate that the module is present.
 Mod-Def 1 is the clock line of two wire serial interface for serial ID.
 Mod-Def 2 is the data line of two wire serial interface for serial ID.
4. LOS is an open collector output, which should be pulled up with a 4.7k~10kΩ resistor. Pull up voltage between 2.0V and Vcc+0.3V. Logic 1 indicates loss of signal: Logic 0 indicates normal operation. In the low state, the output will be pulled to less than 0.8V.
5. RD-/+ : These are the differential receiver outputs. They are internally AC-coupled 100 differential lines which should be terminated with 100Ω (differential) at the user SERDES.
6. TD-/+ : These are the differential transmitter inputs. They are internally AC-coupled, differential lines with 100Ω differential termination inside the module.

Block Diagram of Transceiver

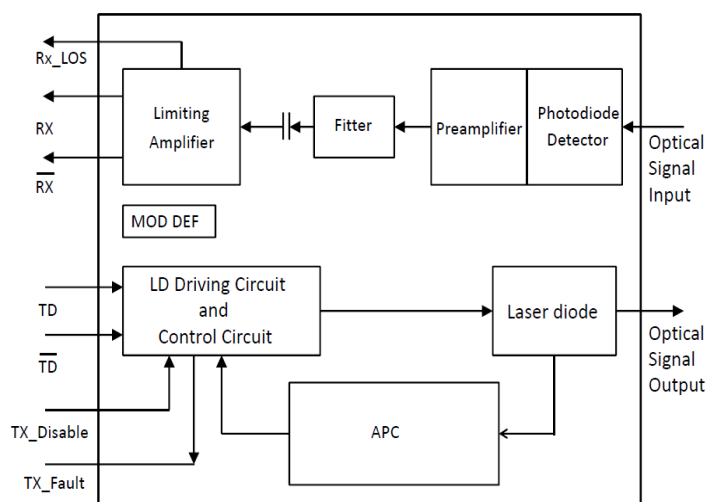

Block Diagram of Transceiver

TITLE

**1Gbps SFP Bi-Directional Transceiver, 40km Reach
1550nm TX / 1310 nm RX**

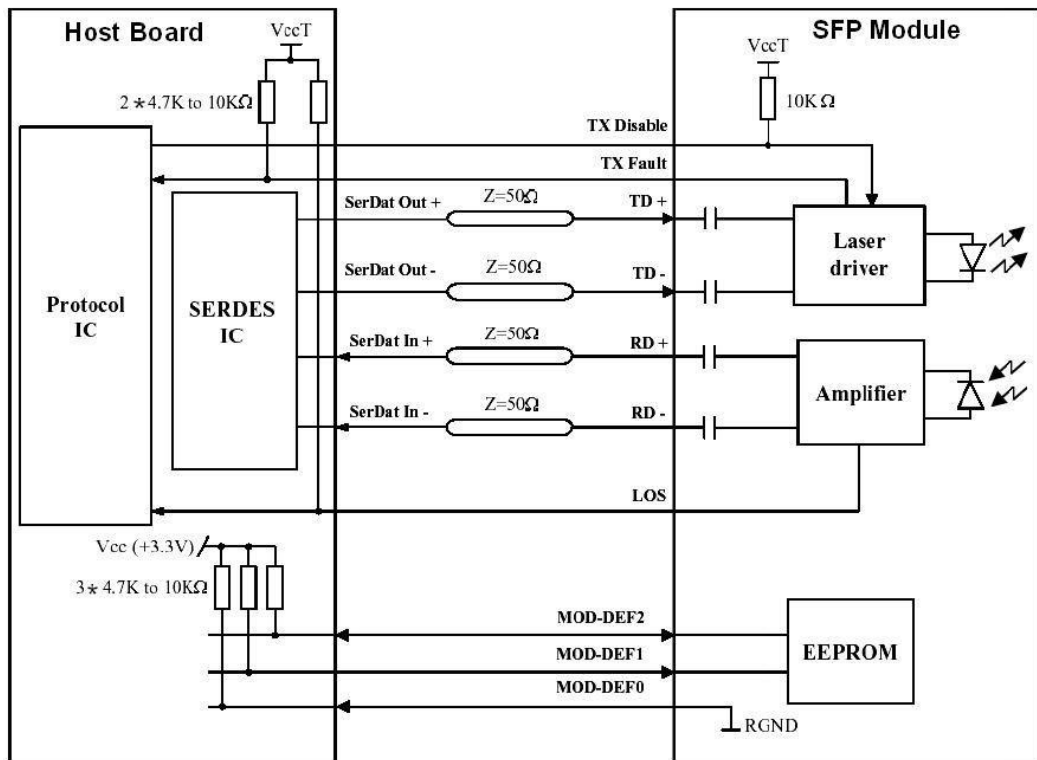

Recommended Interface Circuit